

E-1 曲轴箱总成 CRANKCASE ASSY

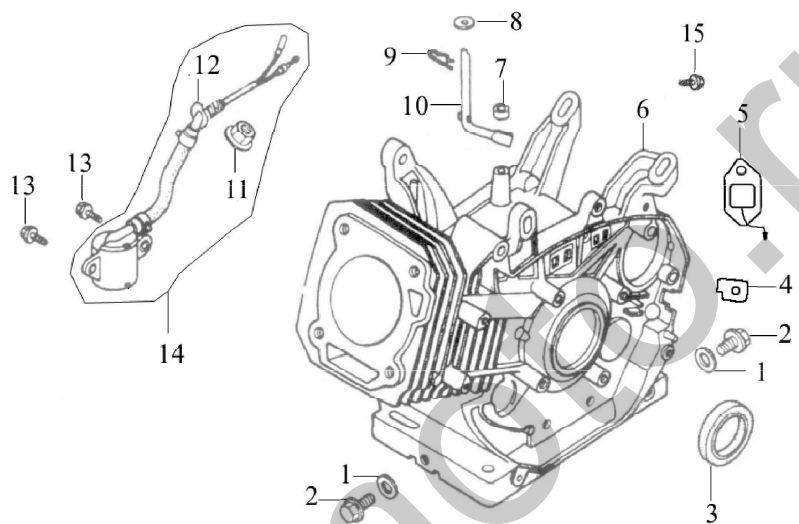

序号 S/N	零部件代号 Part No.	零部件名称	Description	数量 Quantity	备注 Remark
1	11116/173F	放油螺塞垫圈	Washer	2	
2	11115/173F	放油螺塞	Drain plug	2	
3	11120	曲轴油封	Oil seal, crankshaft	1	
4	11117/173F	曲轴箱橡胶圈	Seal	1	
5	27500/168F	单向导通器	Diode	1	
6	11100	曲轴箱组合	Crankcase	1	
7	11130	调速摆杆油封	Oil seal, regulating sway bar	1	
8	26113/173F	调速摆杆垫片	Washer	2	
9	26112/173F	调速摆杆锁夹	Split pin	1	
10	26111	调速摆杆	Regulating sway bar	1	
11	GB/62-1988	螺母 M10	Nut M10	1	
12	11119	O型密封圈 13×1.4	O-ring	1	
13	GB/T16674-1996	螺栓 M6×14-F	Bolt M6×14-F	2	
14	27400/168F	机油传感器	Oil sensor	1	
15	GB/T16674-1996	螺栓 M6×12-F	Bolt M6×12-F	1	

E-2 曲轴箱盖组件 CRANKCASE COVER ASSY

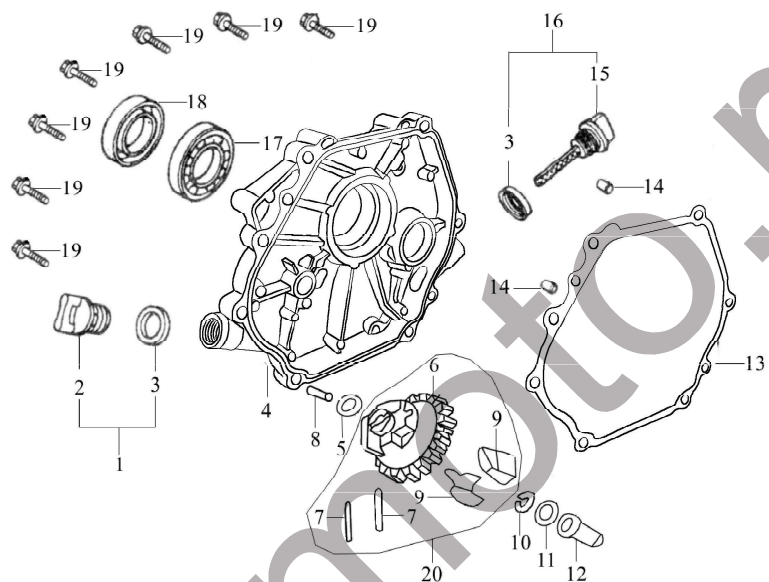

序号 S/N	零部件代号 Part No.	零部件名称	Description	数量 Quantity	备注 Remark
1	15520/173F	机油塞组件	Oil plug with Seal	1	
2	15521/173F	机油塞	Oil plug	1	
3	15512/173F	机油尺密封圈	Seal	2	
4	11211	曲轴箱盖	Crankcase cover	1	
5	25118/173F	调速从动齿轮垫片	Washer, driven gear	1	
6	25111	调速从动齿轮	Driven gear, regulator	1	
7	25116/173F	飞块销	Pin	2	
8	25115/173F	调速轴	Regulating shaft	1	
9	25114	调速飞块	Flying block	2	
10	25117/173F	调速轴卡圈	Snap ring	1	
11	25113/168F	调速滑套垫片	Washer	2	
12	25112/173F	调速滑套	Sliding sleeve	1	

E-2 曲轴箱盖组件 CRANKCASE COVER ASSY

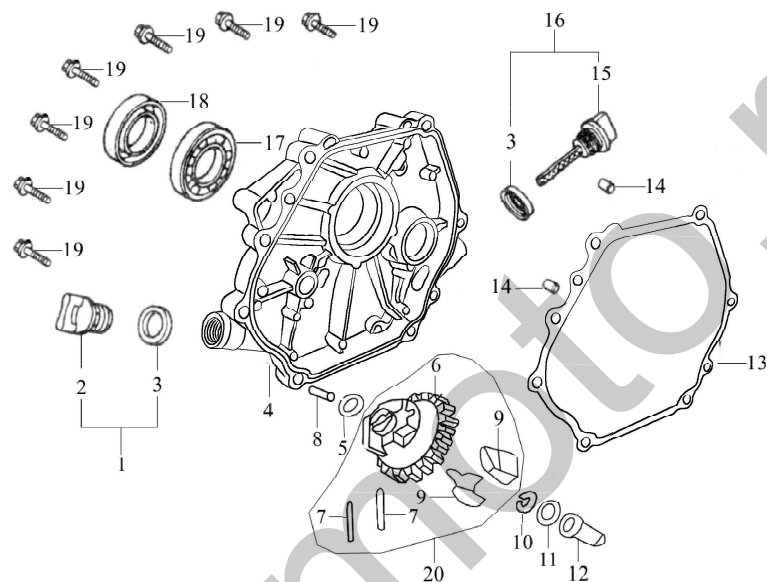

序号 S/N	零部件代号 Part No.	零部件名称	Description	数量 Quantity	备注 Remark
13	11114	曲轴箱垫片	Gasket, crankcase	1	
14	11113/173F	定位销Φ8×12	Set pin Φ8×12	2	
15	15511/173F	机油尺	Dipstick	1	
16	15510/173F	机油尺组件	Dipstick with seal	1	
17	GB276-89	轴承 6207	Bearing 6207	1	
18	11120	曲轴油封	Oil seal, crankshaft	1	
19	GB/T16674-1996	螺栓 M8×35-F	Bolt M8×35-F	7	
20	25100	调速从动齿轮组件	Driven gear, regulator assy	1	

E-3 气缸头 气缸头盖总成 CYLINDER HEAD & CYLINDER HEAD COVER ASSY

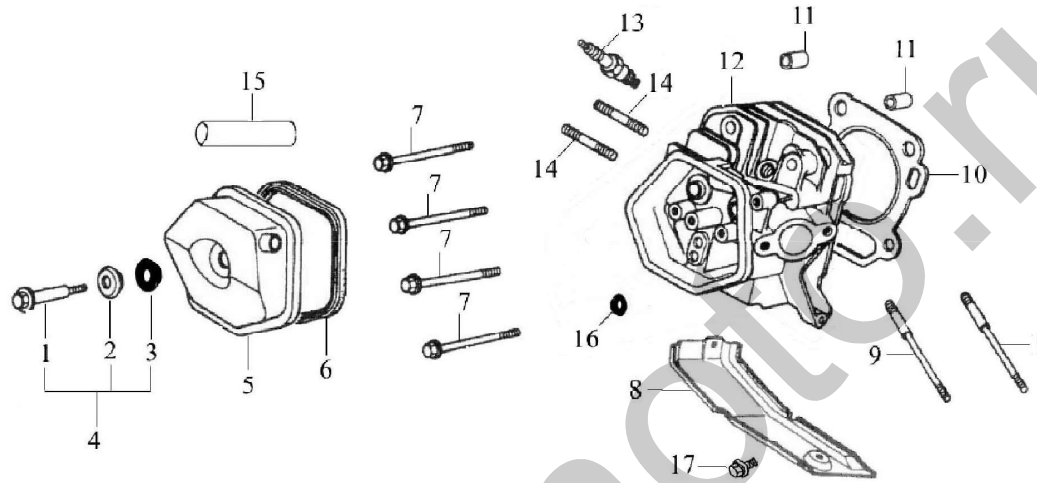

序号 S/N	零部件代号 Part No.	零部件名称	Description	数量 Quantity	备注 Remark
1	12221/173F	气缸头盖螺栓	Bolt	1	
2	12222/173F	气缸头盖螺栓垫圈	Washer	1	
3	12223/173F	橡胶圈	Rubber seal	1	
4	12220/173F	气缸头盖螺栓组件	Bolt	1	
5	12200/173F	气缸头盖组合	Cylinder head cover Assy	1	
6	12212/173F	气缸头盖密封圈	Gasket, cylinder head cover	1	
7	12118/173F	气缸头螺栓	Bolt	4	
8	19112	下导风罩	Lead wind cover	1	
9	17218	进气口双头螺栓	Stud	2	
10	12121	气缸头密封垫	Gasket, cylinder head	1	
11	12117/173F	气缸头定位销	Set pin	2	
12	12100	气缸头组合	Cylinder head Assy	1	

E-3 气缸头 气缸头盖总成 CYLINDER HEAD & CYLINDER HEAD COVER ASSY

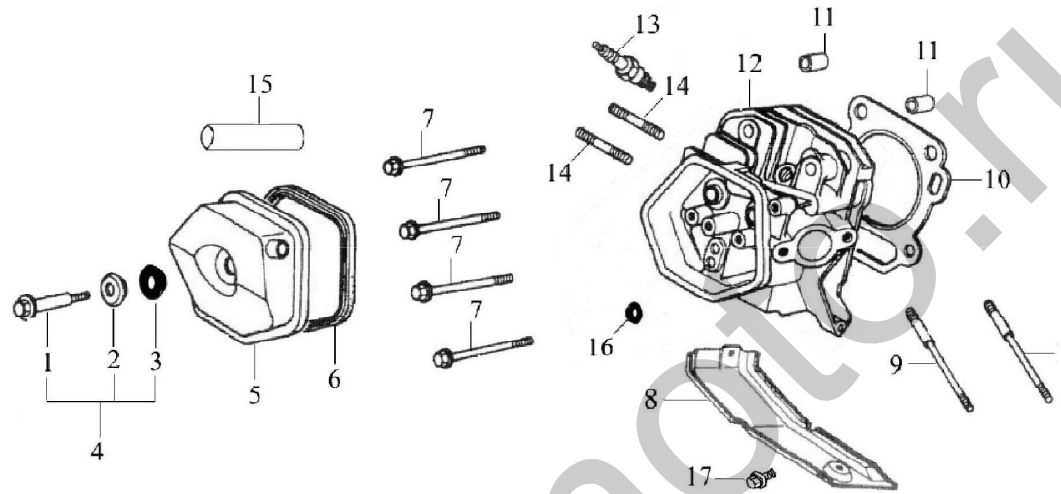

序号 S/N	零部件代号 Part No.	零部件名称	Description	数量 Quantity	备注 Remark
13	27100/168F	火花塞 F6RTC	Spark plug F6 RTCU	1	
14	18241/173F	排气口双头螺栓	Stud	2	
15	17217/173F	通气管	Air duck	1	
16	14420/173F	挡油罩	Seal	1	
17	GB/T16674-1996	螺栓 M6×12-F	Bolt:M6×12-F	1	

E-4 曲轴 活塞连杆 平衡轴总成 CRANKSHAFT, PISTON, CONNECTING & BALANCING SHAFT

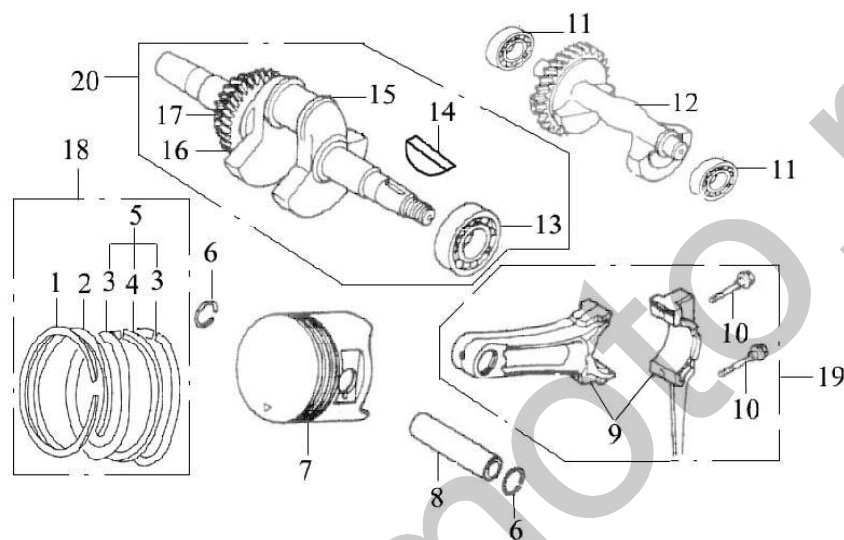

序号 S/N	零部件代号 Part No.	零部件名称	Description	数量 Quantity	备注 Remark
1	13411	活塞环 (一)	Piston ring (I)	1	
2	13412	活塞环 (二)	Piston ring (II)	1	
3	13422	侧环	Side rail	2	
4	13421	衬簧	Expander	1	
5	13420	油环组合	Scrapers ring set	1	
6	13313	活塞销挡圈	Piston pin circlip	2	
7	13311	活塞	Piston	1	
8	13312	活塞销	Piston pin	1	
9	13200	连杆	Shank	1	
10	13213/173F	连杆螺栓	Bolt	2	
11	GB276-89	轴承 6202	Bearing 6202	2	
12	13116	平衡轴	Balancing shaft	1	
13	GB276-89	轴承 6207	Bearing 6207	1	

E-4 曲轴 活塞连杆 平衡轴总成 CRANKSHAFT, PISTON, CONNECTING & BALANCING SHAFT

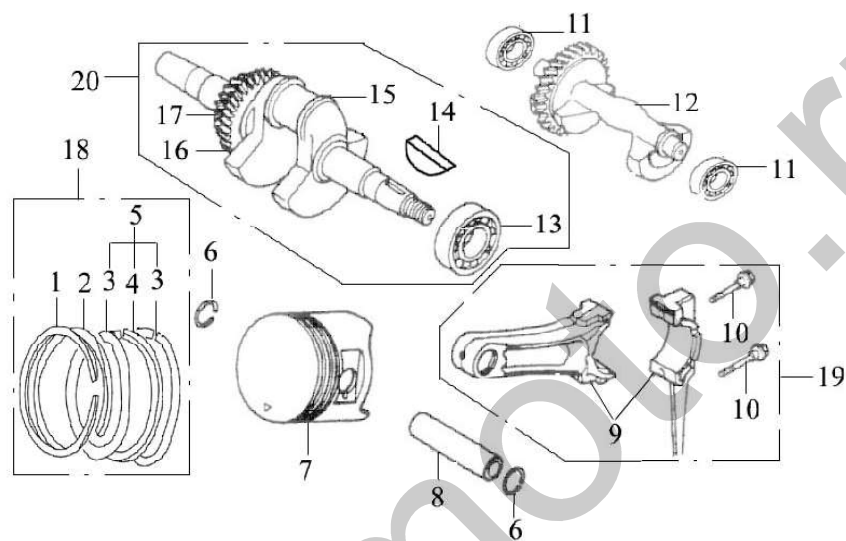

序号 S/N	零部件代号 Part No.	零部件名称	Description	数量 Quantity	备注 Remark
14	13112/173F	半圆键	Wood ruff key	1	
15	13111	曲轴	Crankshaft	1	
16	13114	调速主动齿轮	Drive gear	1	
17	13113	正时主动齿轮	Timing driving gear	1	
18	13300	活塞环组	Piston ring set	1	
19	13200	连杆组合	Connecting rod assy	1	
20	13100	曲轴组合	Crankshaft assy	1	

E-5 凸轮轴装配组合 气门摇臂组合 COMBINATION OF CAM SHAFT & VALVE ROCKER

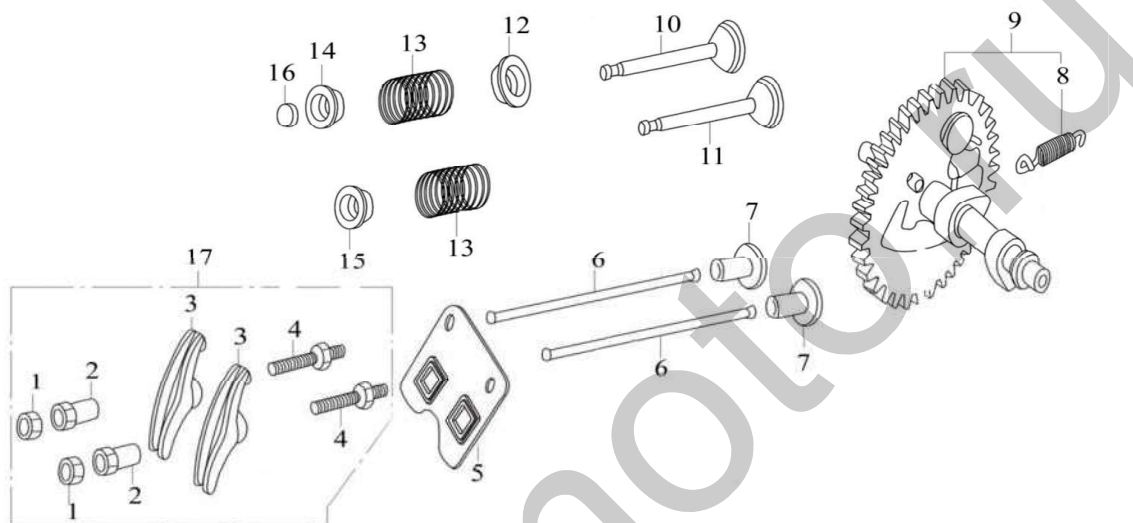

序号 S/N	零部件代号 Part No.	零部件名称	Description	数量 Quantity	备注 Remark
1	14314/173F	气门间隙调节螺母	Lock nut	2	
2	14312/173F	摇臂轴座销	Sleeve	2	
3	14311/173F	气门摇臂	Valve rocker	2	
4	14313/173F	气门间隙调节螺栓	Adjusting bolt for valve gap	2	
5	14221/173F	推杆导架	Pusher guide	1	
6	14210	推杆组合	Pusher	2	
7	14315/173F	挺柱	Tappet	2	
8	14122/173F	飞块弹簧	Extension spring	1	
9	14100	凸轮轴装配组合	Camshaft assy	1	
10	14412	排气门	Exhaust valve	1	
11	14411	进气门	Intake valve	1	
12	14417/173F	排气门弹簧下座	Spring retainer, exhaust valve	1	
13	14414/173F	气门弹簧	Valve spring	2	
14	14415/173F	排气门弹簧座	Spring seat, exhaust valve	1	

E-5 凸轮轴装配组合 气门摇臂组合 COMBINATION OF CAM SHAFT & VALVE ROCKER

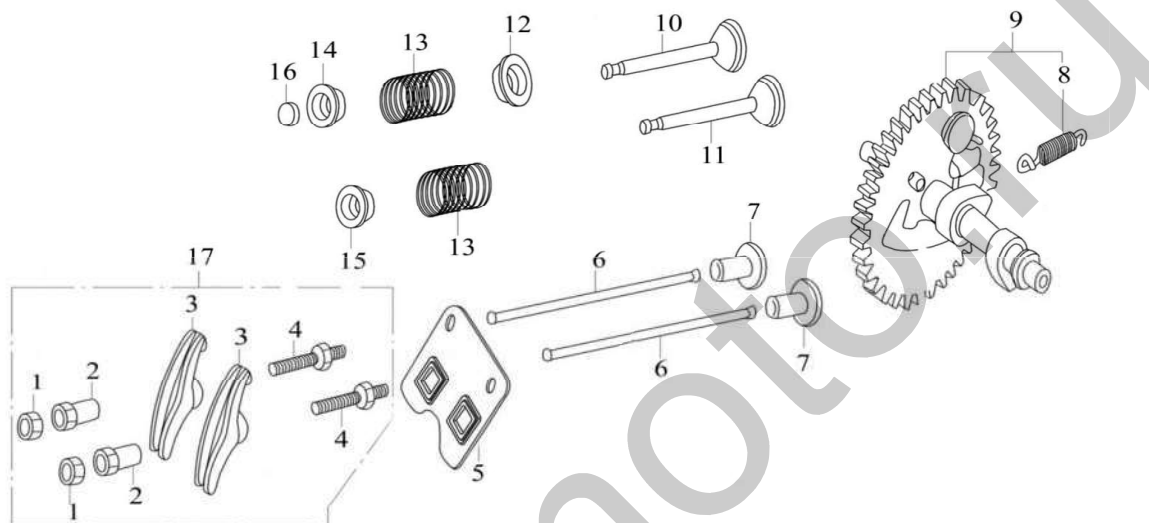

序号 S/N	零部件代号 Part No.	零部件名称	Description	数量 Quantity	备注 Remark
15	14413/173F	进气门弹簧座	Spring seat, intake valve	1	
16	14416/173F	排气门顶帽	Cap	1	
17	14310/173F	气门摇臂装配组合	Valve rocker assy	1	
				2	

E-6 化油器总成 CARBURETOR ASSY

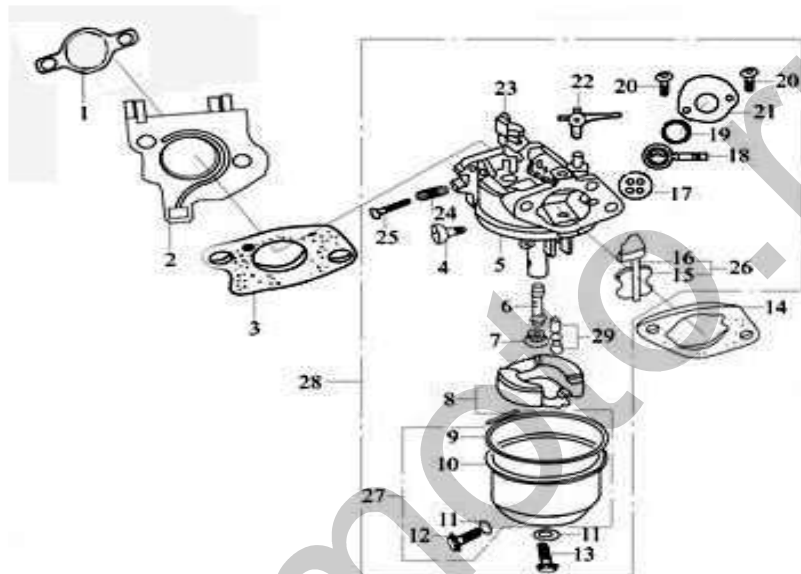

序号 S/N	零部件代号 Part No.	零部件名称	Description	数量 Quantity	备注 Remark
1	17219	进气口垫片	Inlet gasket	1	
2	16112	化油器接块	Connecting block	1	
3	16113	化油器垫片	Carburetor gasket	1	
4	16351/168F	怠速调整螺钉	Idle adjustment screw	1	
5	16240	化油器混合室体	Mixture chamber body	1	
6	16244	主喷油管	Main nozzle	1	
7	16243	主喷油孔	Main jet	1	
8	16220	浮子组合	Float	1	
9	16216/173F	浮子室密封垫	Float chamber gasket	1	
10	16211/173F	浮子室	Float chamber	1	
11	16215/168F	浮子室放油螺钉垫圈	Washer	2	
12	16214/168F	浮子室放油螺钉	Float chamber drain Screw	1	
13	16212/168F	浮子室螺钉	Screw	1	
14	17113/173F	空滤器垫片	Air cleaner gasket	1	

E-6 化油器总成 CARBURETOR ASSY

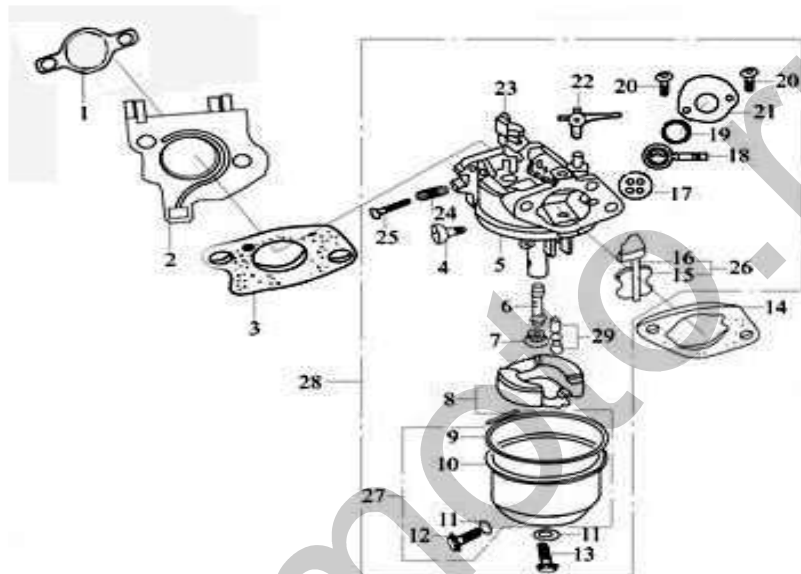

序号 S/N	零部件代号 Part No.	零部件名称	Description	数量 Quantity	备注 Remark
15	16321/173F	阻风门	Choke	1	
16	16322/173F	阻风门轴	Choke stem	1	
17	16365/168F	化油器四孔垫圈	Airproof washer	1	
18	16363/168F	化油器开关手柄	Throttle lever	1	
19	16364/168F	化油器开关密封垫	Washer	1	
20	16367	化油器开关盖螺钉	Screw M4	2	
21	16362/168F	化油器开关盖	Cover	1	
22	16114/173F	阻风门开关	Choke switch	1	
23	16250	节气门组合	Throttle unit	1	
24	16332/168F	混合比调整螺钉弹簧	Spring, mixture adjustment screw	1	
25	16331/168F	混合比调整螺钉	Mixture adjustment screw	1	
26	16320/173F	阻风门组合	Choke unit	1	
27	16210/173F	浮子室组合	Float chamber	1	
28	16100	化油器总成	Carburetor Assy	1	
29	16230	浮子油针组合	Float needle	1	

E-7 燃油箱组成 FUEL TANK ASSY

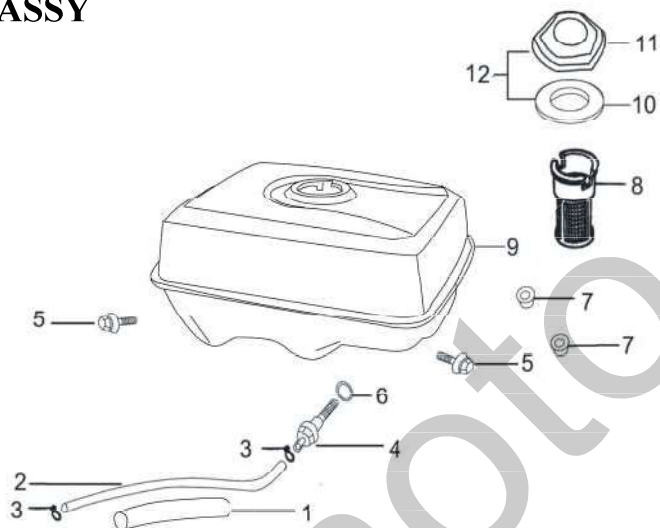

序号 S/N	零部件代号 Part No.	零部件名称	Description	数量 Quantity	备注 Remark
1	16626/173F	油管保护套	Pipe	1	
2	16621/173F	出油管 (一)	Outlet pipe	1	
3	16622/168F	油管夹 (二)	Pipe clamp	2	
4	16633/168F	出油接头	Connector	1	
5	GB5789-86	螺栓 M8×25	Bolt M8×25	2	
6	16634/168F	出油接头密封圈	Packing ring	1	
7	GB6170-2000	螺母 M8	Nut M8	2	
8	16610/168F	过滤杯	Filter cup	1	
9	16510	燃油箱组件	Fuel tank	1	
10	16414/168F	密封垫圈	Packing ring	1	
11	16411/168F	燃油箱盖	Fuel filler cap	1	
12	16400/168F	燃油箱盖组合	Fuel filler cap with packing ring	1	

E-8 空气滤清器总成 AIR CLEANER ASSY

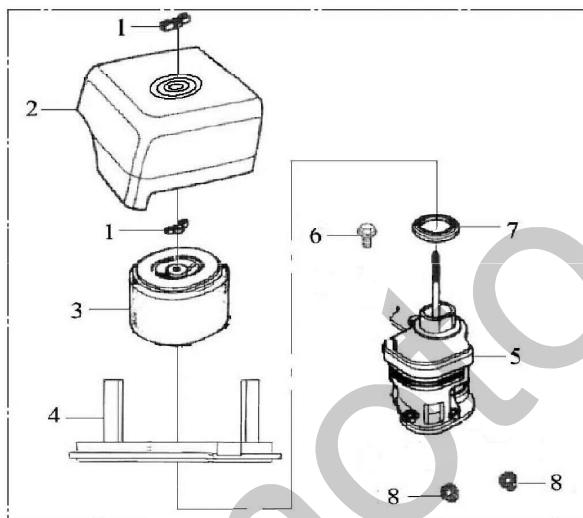

序号 S/N	零部件代号 Part No	零部件名称	Description	数量 Quantity	备注 Remark
1	17111	空滤器盖螺母	Air cleaner cover nut	2	
2	17112	空滤器盖	Air cleaner cover	1	
3	17120	滤芯组件	Filter element	1	
4	17114	空滤器本体	Air cleaner base	1	
5	17200/173F	进气管组合	Air cleaner housing assy	1	
6	GB5789-86	空滤器座紧固螺栓 M6×22	Bolt M6×22	1	
7	17121/173F	垫圈	Washer	1	
8	GB6177.1-2000	螺母 M6(法兰)	Nut M6(Flange)	2	
9	17100	空滤器总成	Air cleaner assy	1	

E-9 消声器组件 MUFFLER

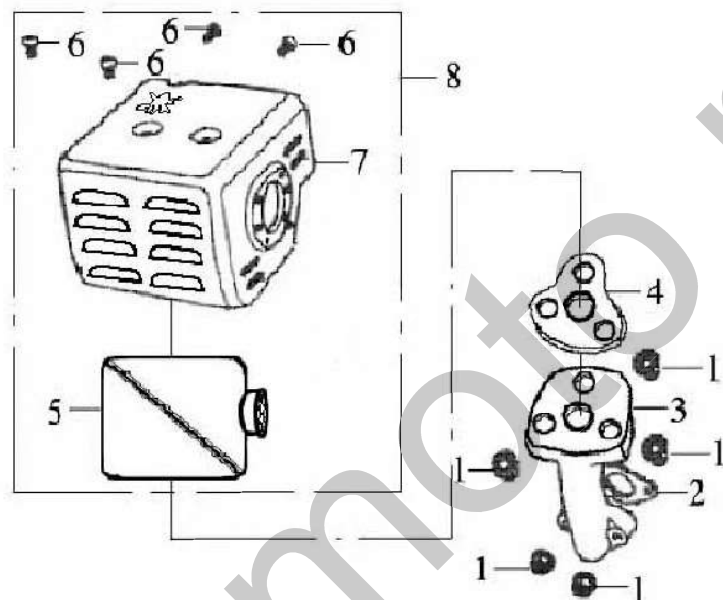

序号 S/N	零部件代号 Part No	零部件名称	Description	数量 Quantity	备注 Remark
1	GB6183-86	螺母 M8	Nut M8	5	
2	18117/173F	排气口垫片	Exhaust pipe gasket	1	
3	18215/173F	排气管	Exhaust pipe	1	
4	18217/173F	消声器垫片	Muffler gasket	1	
5	18100	消声器	Muffler	1	
6	GB818-2000	螺钉 M5×8	Screw M5×8	4	
7	18200	消声器护罩组合	Muffler hood assy	1	
8	18000	消声器总成	Muffler assy	1	

E-10 反冲起动器部件 RECOIL STARTER

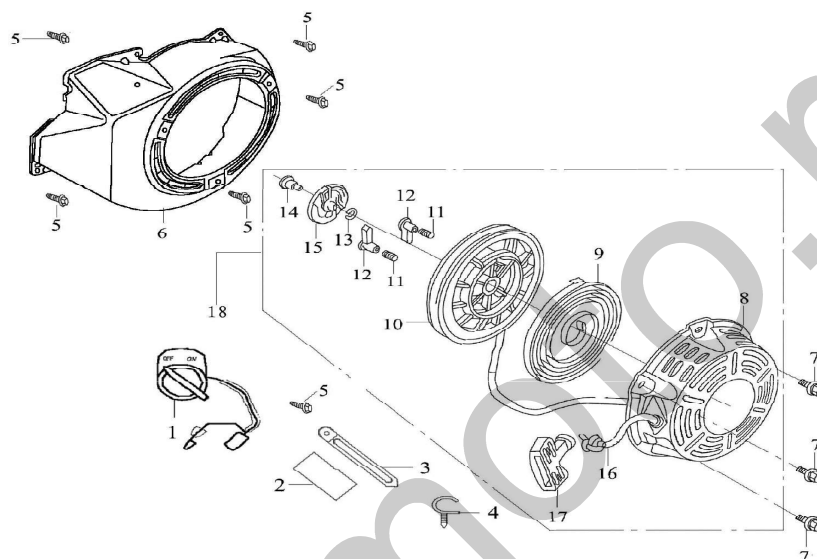

序号 S/N	零部件代号 Part No	零部件名称	Description	数量 Quantity	备注 Remark
1	31225/168F	点火开关	Engine switch	1	
2	19314/173F	护线套	Wire grommet	1	
3	19316/173F	固线卡	Clip	1	
4	16625/173F	塑料管夹	Plastic clip	1	
5	GB/T16674-1996	螺栓 M6×12-F	Bolt M6×12-F	6	
6	19200	风扇罩组件	Fan hood assy	1	
7	GB/T16674-1996	螺栓 M6×8-F	Bolt M6×8-F	3	
8	23211	外壳组件	Casing	1	
9	23114	盘簧	Spiral spring	1	
10	23117	起动器卷轴	Starter rolls	1	
11	23112/173F	棘爪弹簧	Ratchet spring	2	
12	23115/173F	棘爪	Ratchet	2	
13	23111/173F	摩擦弹簧	Friction spring	1	
14	23113/173F	轴位螺钉	Set screw	1	

E-10 反冲起动器部件 RECOIL STARTER

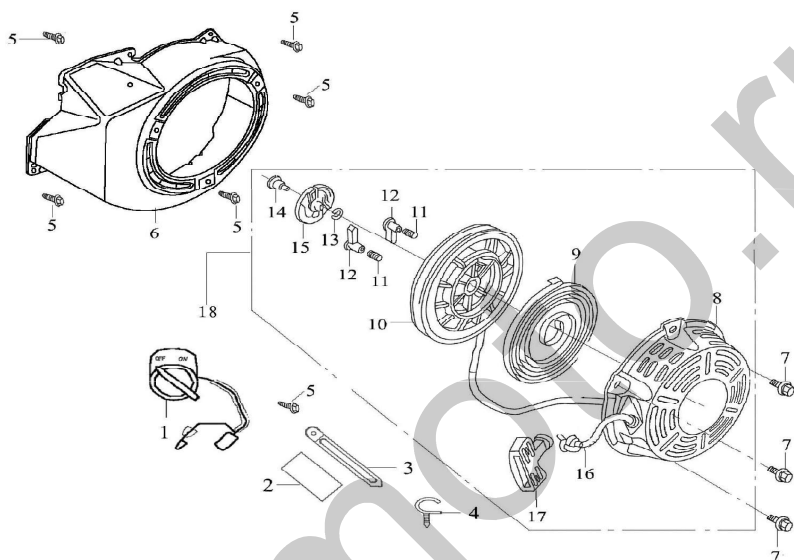

序号 S/N	零部件代号 Part No	零部件名称	Description	数量 Quantity	备注 Remark
15	23116/173F	弹簧盖	Spring lid	1	18 存在 争议
16	23118	拉绳	Rope	1	
17	23121/168F	拉手	Pulling handle	1	
18	23100	反冲起动器总成	Recoil starter assy	1	

E-11 调速控制系统 REGULATING CONTROL SYSTEM

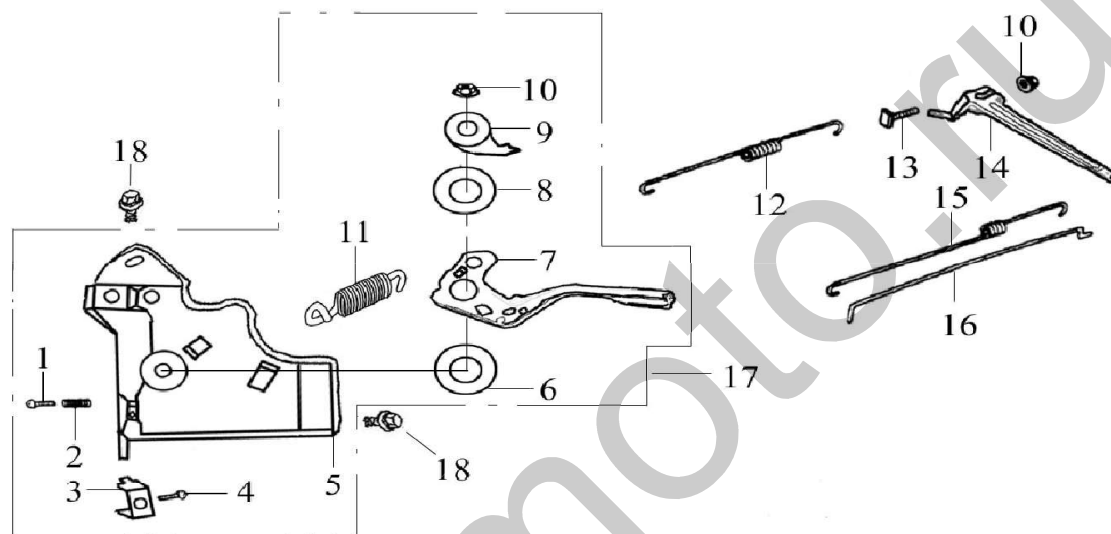

序号 S/N	零部件代号 Part No	零部件名称	Description	数量 Quantity	备注 Remark
1	GB/T818-2000	螺栓 M5×35	Bolt M5×35	1	
2	26215/173F	调速弹簧	Regulating spring	1	
3	26213/173F	压板	Clamp	1	
4	GB/T818-2000	螺栓 M5×16	Bolt M5×16	1	
5	26211	调速支撑板	Support panel	1	
6	26222/173F	垫圈	Washer	1	
7	26221	手柄	Handgrip	1	
8	26223/173F	弹簧片	Spring patch	1	
9	26224/173F	定位板	Setting panel	1	
10	GB6177.1-2000	螺母 M6(法兰)	Nut M6(Flange)	2	
11	26214/173F	拉簧	Spring	1	
12	26117	复位弹簧	Back spring	1	
13	26116/168F	调速臂紧固螺栓	Lock bolt	1	
14	26114	调速臂	Regulating arm	1	

E-11 调速控制系统 REGULATING CONTROL SYSTEM

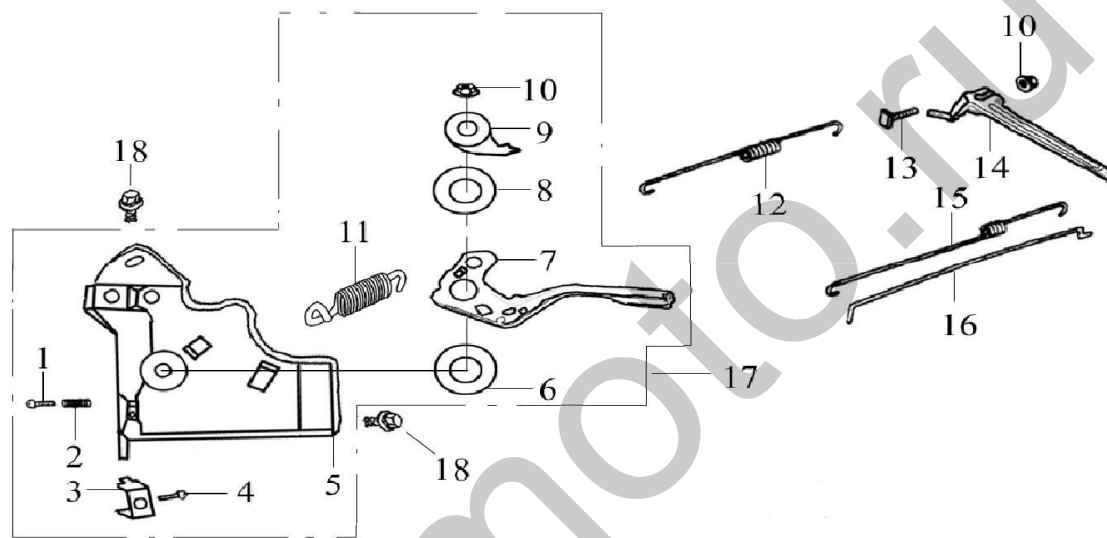

序号 S/N	零件代号 Part No	零件名称	Description	数量 Quantity	备注 Remark
15	26118	微调速弹簧	Fine regulating spring	1	
16	26115	调速拉杆	Pulling rod	1	
17	26200	调速架部件	Regulating frame assy	1	
18	GB/T16674-1996	螺栓 M6×12-F	Bolt M6×12-F	2	

E-12 飞轮部件 FLYWHEEL

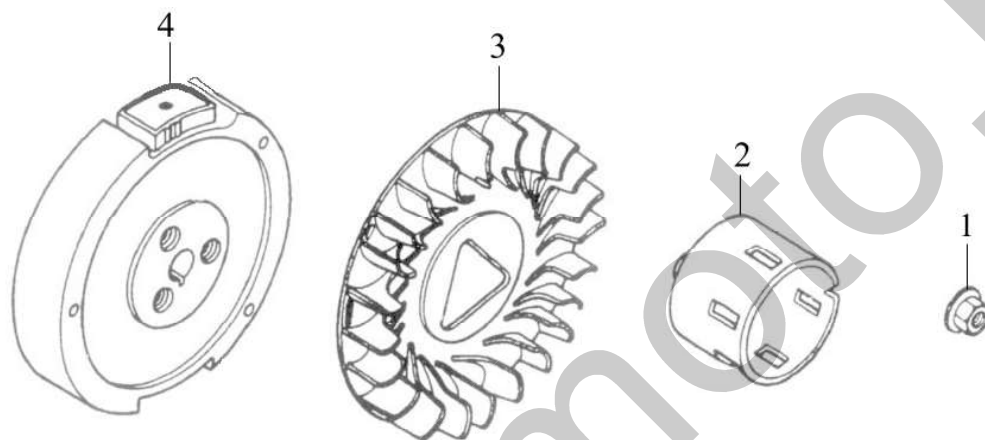

序号 S/N	零部件代号 Part No	零部件名称	Description	数量 Quantity	备注 Remark
1	23317/173F	飞轮螺母 M16×1.25	Nut M16×1.25	1	
2	23316	起动套	Starting flange	1	
3	19111	飞轮风扇	Flywheel fan	1	
4	23300	飞轮组件	Flywheel	1	

E-13 点火线圈组件 IGNITION COIL

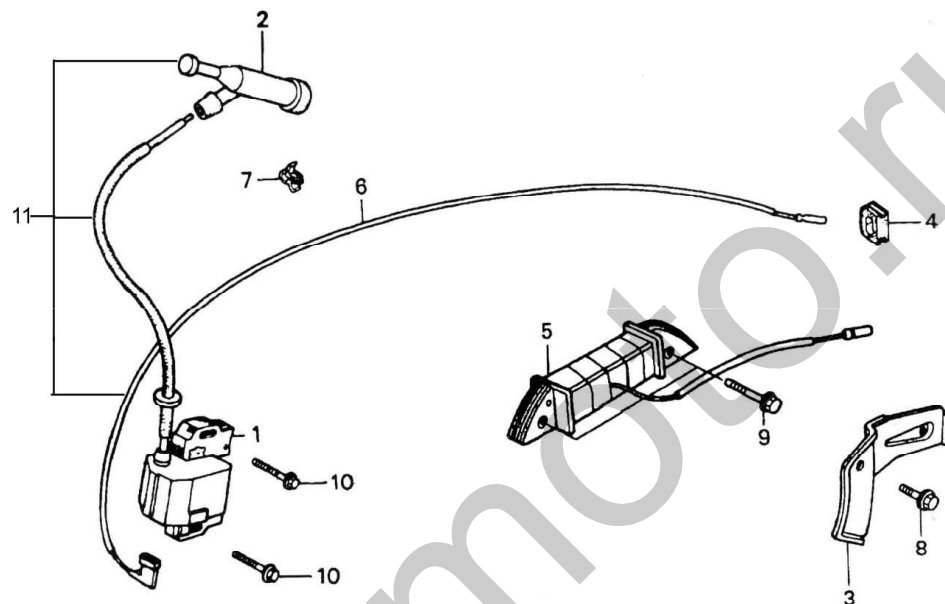

序号 S/N	零部件代号 Part No	零部件名称	Description	数量 Quantity	备注 Remark
1	27200	点火线圈	Ignition coil	1	
2	27220	火花塞帽	Cap, spark plug	1	
3	11213	压线板	Clamper, cord	1	
4	11124/173F	曲轴箱橡胶圈	Rubber ring, crankcase	1	
5	31250/182F-AS	充电定子组件	Charge coil	1	
6	34410/182F	熄火线	Extinguishing cable	1	
7	32212/173F	线夹	Cable tie	1	
8	GB5787-86	螺栓 M6×12	Bolt, M6×12	1	
9	GB5787-86	螺栓 M6×35	Bolt, M6×35	2	
10	GB5787-86	螺栓 M6×30	Bolt, M6×30	2	
11	27210	点火线圈组件	Ignition coil unit	1	

E-14 起动电机部件 STARTING MOTOR ASSY

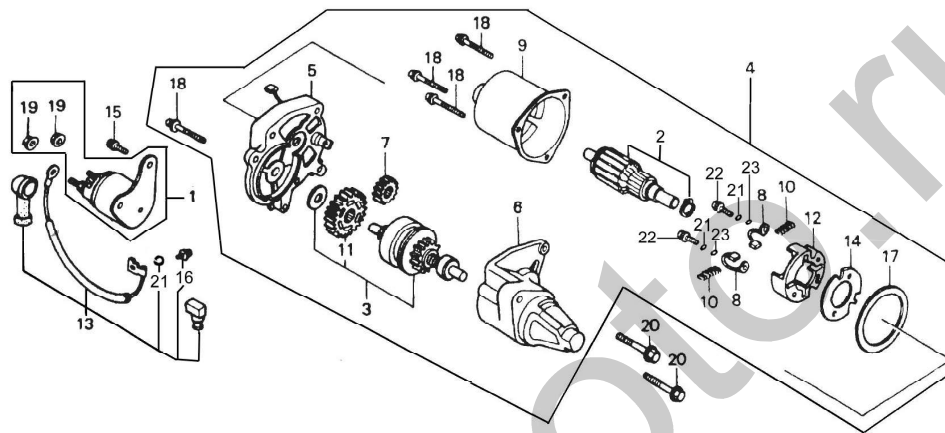

序号 S/N	零部件代号 Part No.	零部件名称	Description	数量 Quantity	备注 Remark
1	24120	起动继电器	Relay, start-up	1	
2	35200	转子组件	Rotor comp.	1	
3	21000	起动离合器	Starting clutch	1	
4	24000	电起动总成	Starting motor Assy	1	
5	28650	起动电机座	Base, starting	1	
6	28110	起动离合器壳	Housing, starting clutch	1	
7	22123	主动齿轮	Driven gear	1	
8	35230	电刷组件	Brush comp.	4	
9	35210	定子组件	Stator comp.	1	
10	28631	电刷弹簧	Spring, brush	4	
11	28321	减速齿轮	Reducing gear	1	
12	31131	电刷支架	Stay, brush	1	
13	32160	起动电机线	Cable, starting motor	1	
14	28632	绝缘块	Insulator	1	
15	31996	螺栓 M5×14	Bolt, M5×14	2	
16	GB818-85	螺钉 M4×6	Screw, M4×6	1	

E-14 起动电机部件 STARTING MOTOR ASSY

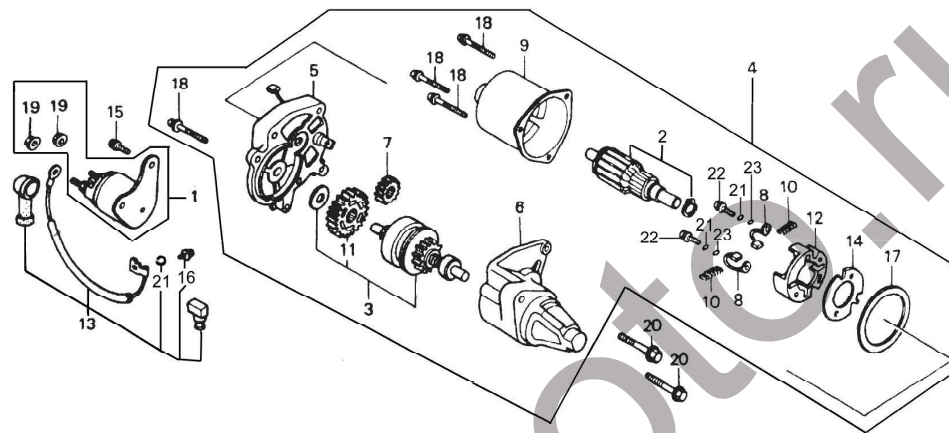

序号 S/N	零部件代号 Part No.	零部件名称	Description	数量 Quantity	备注 Remark
17	28651	密封胶圈	Packing ring	1	
18	GB818-85	螺钉 M5×32	Screw M5×32	4	
19	GB6170-86	螺母 M6	Nut M6	2	
20	GB5787-86	螺栓 M6×35	Bolt M6×35	2	
21	GB93-87	弹垫 4	Spring washer 4mm	3	
22	GB818-85	螺钉 M4×14	Screw M4×14	2	
23	GB97. 1-85	平垫 4	Washer 4mm	2	

E-15 启动控制盒总成(选用) STARTING MOTOR CONTROL BOX ASSY

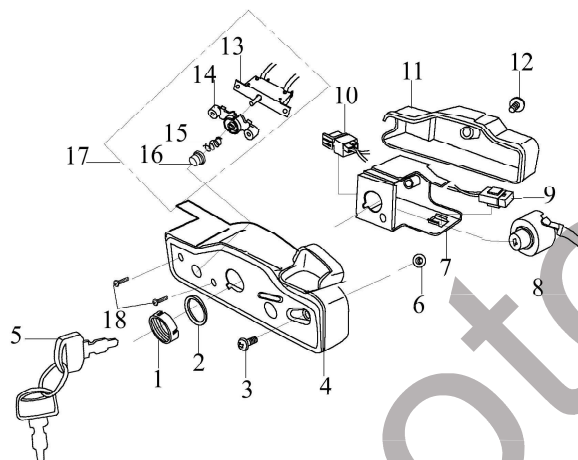

序号 S/N	零部件代号 Part No.	零部件名称	Description	数量 Quantity	备注 Remark
1	24217	锁紧圈	Clamp ring	1	
2	24218	钥匙开关垫圈	Gasket	1	
3	GB818-86	螺栓 M4×10	Bolt M4×10	1	
4	24211	控制盒前盖	Control front cover	1	
5	31258	钥匙	Key	1	
6	GB6187-86	六角法兰锁紧螺母 M4	Nut M4	1	
7	24121	控制盒内支撑架	Fixed mount	1	
8	24215	启动钥匙开关	Key switch	1	
9	24230	保险	Safety	1	
10	24225	二极管组合	Diode assy	1	
11	24213	控制盒后盖	Control rear cover	1	
12	24214	后盖连接螺栓	Attachment bolt	1	
13	24221	线路保护器	Protector	1	
14	24222	线路保护器支架	Fixed mount	1	
15	31343	弹簧	Spring	1	

E-15 启动控制盒总成(选用) STARTING MOTOR CONTROL BOX ASSY

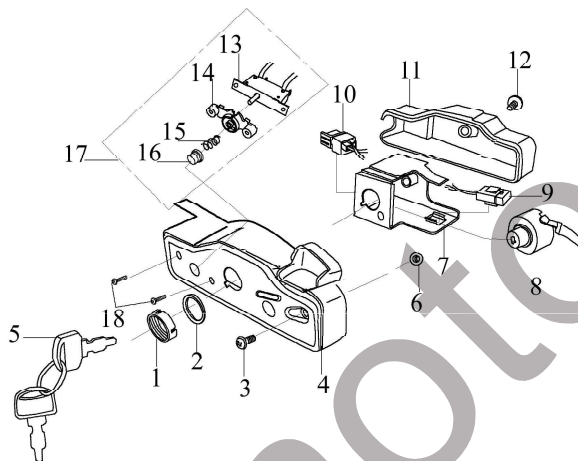

序号 S/N	零部件代号 Part No.	零部件名称	Description	数量 Quantity	备注 Remark
16	24224	线路保护器帽	Cover	1	
17	24220	线路保护器组合	Protector assy	1	
18	GB818-85	十字半圆头螺钉 M3×12	Bolt M3×12	2	

E-16 贴花 EMBLEM

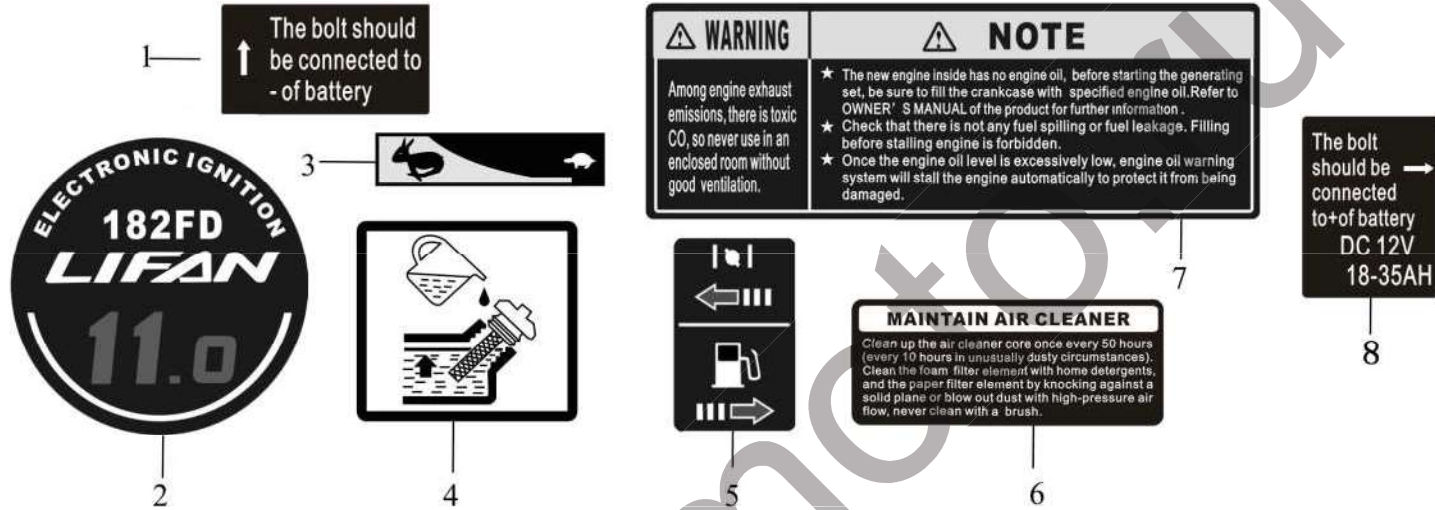

序号 S/N	零部件代号 Part No	零部件名称	Description	数量 Quantity	备注 Remark
1	91149	负极贴花	Emblem, “-” pole	1	
2	91111	型号贴花	Model label	1	
3	91114	龟兔贴花	Emblem, tortoise and rabbit	1	
4	91112	加注机油贴花	Emblem, adding oil	1	
5	91115	阻风门开关贴花	Emblem, choke lever	1	
6	91113	空滤器保养贴花	Emblem, maintenance of air cleaner	1	
7	91118	注意和警告贴花	Emblem, Note or Warning	1	
8	91148	正极贴花	Emblem, “+” pole	1	